

DOT ILLUMINATED PUSHBUTTON

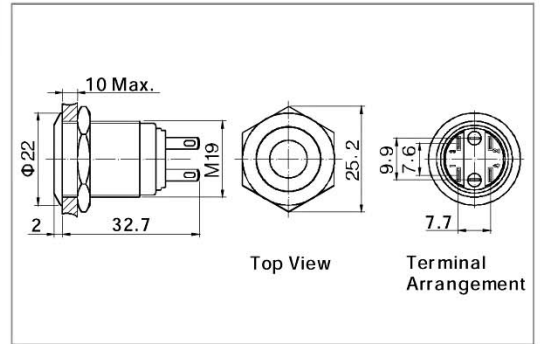

- ⊙ Φ19mm diameter
- ⊙ 5A/250VAC
- ⊙ 1NO1NC
- ⊙ The crust material:Stainless Steel
- ⊙ Dot Illuminated
- ⊙ IP Degree:IP65

AVSLAS1GQ-11□ D



RING ILLUMINATED PUSHBUTTON

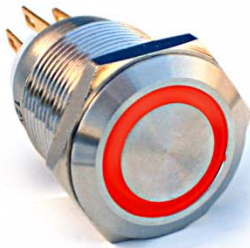

- ⊙ Φ19mm diameter
- ⊙ 5A/250VAC
- ⊙ 1NO1NC
- ⊙ The crust material:Stainless Steel
- ⊙ Ring Illuminated
- ⊙ IP Degree:IP65

AVSLAS1GQ-11□ E

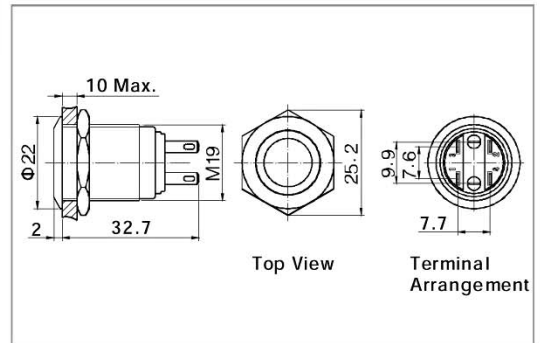

Specification	AVSLAS1GQ-11□ D	AVSLAS1GQ-11 □ E
The Front Shape	Flat Round	Flat Round
Terminal Type	Pin Terminal(2.8×0.5mm)	Pin Terminal(2.8×0.5mm)
Switching	No.2	No.2
Max. Switch Rating	5A/250VAC	5A/250VAC
Contact Resistance	≤ 50mΩ	≤ 50mΩ
Insulation Resistance	≥ 1000MΩ	≥ 1000MΩ
Dielectric Strength	2000VAC	2000VAC
Operation Temp.	-20°C ~ +70°C	-20°C ~ +70°C
Mechanical Life	1,000,000cycles	1,000,000cycles
Electrical Life	50,000 cycles	50,000 cycles
Contact Material	Silver Alloy	Silver Alloy
Panel Thickness	1 ~ 10mm	1 ~ 10mm
Torque	5 ~ 14Nm	5 ~ 14Nm
Operation Pressure	5.5N	5.5N
IP Degree	IP65	IP65
Material	Button	Stainless Steel
	Body	Stainless Steel
	Base	PBT
	RoHS	Made to order
LED Spec.	Type	Dot Illuminated(LED)
	Rated Voltage	6V / 12V / 24V / 110V / 220V
	Color	R G Y O B W
	Life	40,000 hours

Introduction of product model refer to P1