

Snap-in / CS

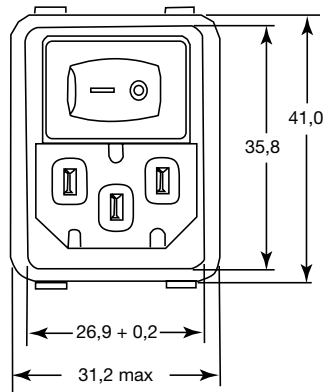

Flange / CE

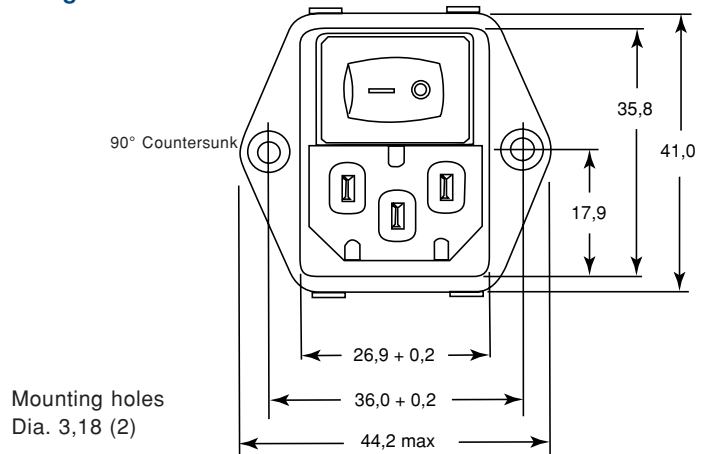

Filtered / CFS, CFE

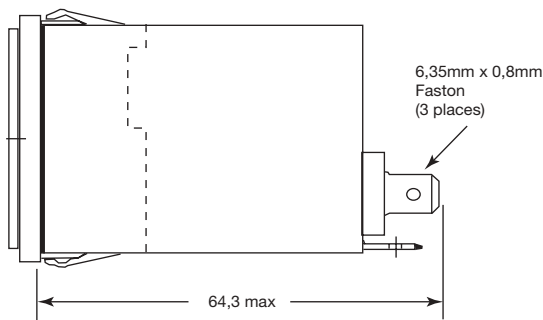

Unfiltered / CS, CE

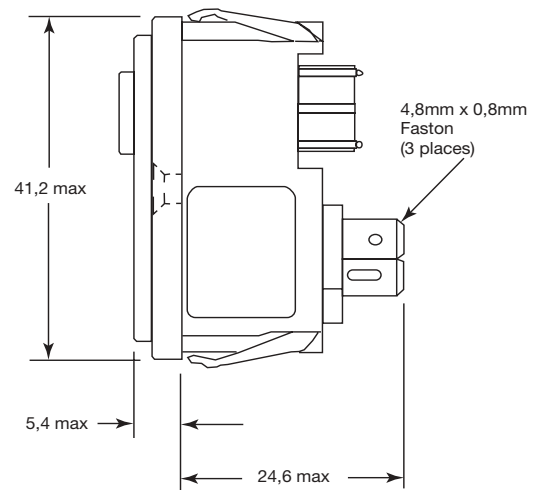

Panel cutout for CS, CE (CFE)

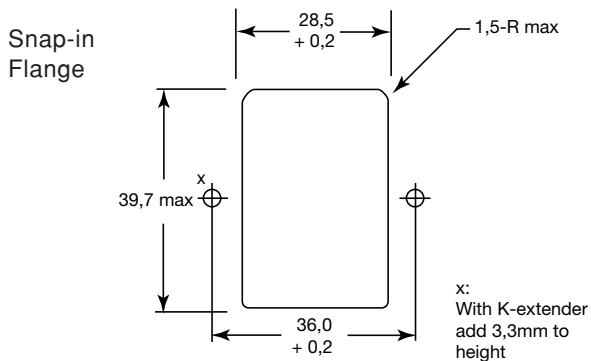

Panel cutout for thickness of 0,8-2,5mm. Not recommended for plastic panels.

For snap-in application, the D sides of the cutout must have a 0,5mm radius on the installation side.

Snap-in models allow front mounting only.

Accessories for C-Series

Available extenders are:

- PA420** - extender C increases height by 5,1mm
- PA400** - extender J increases height by 10,7mm
- CA430** - extender K increases height by 3,3mm